

Manufacture of hybrid pieces using recycled R-PET, polypropylene PP and cocoa pod husks ash CPHA, by pneumatic injection controlled with LabVIEW Software and Arduino Hardware.

A D Rincón-Quintero^{1,2}, L A Del Portillo-Valdés², A Meneses-Jacomé¹, C G Cárdenas-Arias¹, C L Sandoval-Rodriguez¹, J G Ascanio-Villabona¹, B E Tarazona-Romero¹, J A Sandoval-Baldión¹, J C Ortiz-Ríos¹, R A Mantilla-Olejua¹

¹ Design and materials research group (DIMAT), Automation and Control Energy Systems Research Group (GISEAC), Electromechanical engineering, Faculty of Natural Sciences and Engineering, Technological Units of Santander (UTS), Calle de los estudiantes No 9-82, 680005, Bucaramanga, Colombia.

² Energy in Building research group (ENEDI), Doctoral Program in Energy Efficiency and Sustainability in Engineering and Architecture, Department of Machines and Thermal Engines, University of the Basque Country (UPV/EHU), Engineer Torres Quevedo Plaza, 1, 48013, Bilbao, BI, España.

arincon@correo.uts.edu.co

Abstract. The research consists of the design and automation of a pneumatic injector, applying LabVIEW software through an integrated Arduino hardware module, programming through an interface, the pressure that guarantees the geometric quality in the models obtained. The final result shows a piece designed in mass fraction with 40% polypropylene resin (PP), 40% recycled polyethylene terephthalate in the form of scales (R-PET) and 20% from cocoa pod husks ash (CPHA). Likewise, the platform allows to define and control the conditions of generation of the product, defining a pattern according to the type and the mass proportion between the resin of PP, R-PET and CPHA. In addition, the design of the mechanical and thermal elements, consisting of the piston and the system of clamp-type resistors, the pneumatic injection means and the raw material feed gate, improve the efficiency and effectiveness of the equipment.

1. Introduction

Polymers are a widely used material in important sectors of the economies at different scales of the territory, they are the synthetic raw material par excellence used to manufacture products that meet the needs of the population[1], however, their impact on The natural environment has consequences that eventually lead to the degradation of natural resources[2].

The industrial processes where this material is handled, is aimed at reducing costs, and the search for methodologies where reuse is part of the process [3][4].

The manufacture of molds on fixed parts with varied industrial destinations demands high quantities of this material [5]. The processes of forming of plastics vary from product to product since they are designed to meet different characteristics such as the creation of geometric parts, parts of cars or bottles for liquid filling, which count from molding or blowing and more complex processes such as extrusion which allows creations of plastic films, profiles, plastic bags among others [6].

In order to have process efficiencies, thermoplastic injection is contemplated, which allows a molding of the material to meet the demands that arise, thus allowing the design of countless pieces [7].

The methodological process consists in the design of the mechanical, thermal and electronic elements. On the one hand, the injection pressure is determined that guarantees the geometric quality of the final model, applying the pascal law. Then, the design of the integral mechanical element is carried out that involves an efficient process of injection of the hybrid piece, based on the conduction of heat in transient regime and the natural convection [8]. Next, the plunger where the mixture of components with the clamp-type resistors that transfer heat by conduction and radiation will be deposited to carry out the fusion, also, the feeding gate, the pneumatic injection system. Next, an interface is developed through LabVIEW software and Arduino hardware for the control and visualization of variables: time, melting temperature and injection pressure, developing an algorithm for data acquisition [9]–[13].

2. Work development

This research integrates components and theoretical bases regarding heat transfer, the design of mechanical elements, the theory that governs the phenomena of pneumatics and process control, being essential to define these scientific areas in a brief but effective way.

As for heat transfer, this science predicts approximately the exchange of energy between two bodies or systems that are in a temperature differential, there are three (3) ways for this phenomenon to occur: Conduction, convection and radiation .

Automation consists of the programming of processes that are developed in a repetitive and precise way, optimizing them through interfaces that can control the variables of interest. All this, based on a control system, composed of elements that regulate and monitor these variables. A useful device in this area is the Arduino hardware, being a programmable device, where behavior or functionality can be changed, by means of commands in a specific language and compatible with certain Software. One of these is LabVIEW (Laboratory Virtual Instrument Engineering Workbench), which is a program with application in automation laboratories due to its versatile characteristics.

The methodology contemplates the definition and properties of the materials used in the research. Also, the procedure carried out to achieve the stated objectives is described step by step.

2.1. Synthetic polymers

These types of polymers result from polymerization processes, from raw materials with a relatively low molecular weight. An important factor in these materials is the melting point [14], represented in Table 1.

Polymers	Melting temperature (°C)
low density polyethylene LDPE	115
high density polyethylene HDPE	137
Polyvinyl chloride PVC	176 – 212
Polypropylene PP	168 – 176
Polystyrene	240

2.2. Polyethylene terephthalate PET

PET is an easy-molding thermosetting plastic when exposed to heat transfer [15][16]; It is commonly used in beverage container containers, which for this specific case represents the interest of this study.

Well, it's about recycling bottles where soda and other food products are packed. This polymer was released in 1941 by Whinfield and Dickinson, after these, increased its production and application at the industry level [17].

PET is a product of terephthalic acid and ethylene glycol and its chemical formula is as follows:

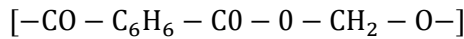

It is a material that has a low molecular weight, its ability to withstand stress is high, has a good physical appearance after making the molds [18]. It is important for the food industry, as it does not affect the taste of food or beverages [19][20]. In addition, it turns out to be economical because it is 100% recyclable. The physical, mechanical, thermal and chemical properties of PET are shown below [21].

Table 2. Physical Properties PET[21]

Physical Properties PET	
Water Absorption - Balance (%)	< 0.7
Density (g/cm ³)	1.3 – 1.4
Refractive Index	1.58 – 1.64
Flammability	Auto extinguishable
UV resistance	Good

Table 3. Mechanical properties PET[21]

Mechanical properties	
Coefficient of friction	0.2 – 0.4
Rockwell Hardness	M94 - 101
Tensile strength (Mpa)	190 - 160
Impact resistance (1/J.m)	13 – 35

Table 4. Thermal Properties PET[21]

Thermal Properties	
Specific heat (KJ/Kg.K)	1.0 – 1.35
Coefficient of thermal expansion (*10 ⁻⁶ K ⁻¹)	20-80
Thermal conductivity (W/K.m)	0.15 – 0.4
Maximum use temperature (°C)	115-170
Minimum use temperature (°C)	-40 - -60
Melting temperature (°C)	230 - 260

Table 5. Chemical properties PET[21]

Chemical properties	
Concentrated acids	Good
Alkalis	Bad
Alcohols	Good
Fats and oils	Good
Halogens	Good
Aromatic hydrocarbons	Acceptable

2.3. Polypropylene PP

It is a thermoplastic that brings together a series of properties that are difficult to find in other material such as: Its high thermal stability allows it to work for a long time at a temperature of 100°C in the air [22].

It is also resistant to boiling water and can be sterilized at temperatures up to 140 °C without fear of deformation.

Advantage:

- Light
- High tensile and compression resistance
- Excellent dielectric properties
- Resistance to most acids and alkalis
- Low moisture absorption coefficient

Structurally it is a vinyl polymer, similar to polyethylene, only one of the carbons of the monomer unit has a methyl group attached[23].

Industrially manufactured polypropylene is a linear polymer, whose backbone is a chain of saturated hydrocarbons. Every two carbon atoms of this main chain, a methyl group (CH₃) is branched. This makes it possible to distinguish three isomeric forms of polypropylene: Isotactic, Syndiotactic, Atactic. These are distinguished by the position of the methyl-CH₃ groups with respect to the spatial structure of the polymer chain.

Isotactic and syndiotactic forms, given their great regularity, tend to acquire an ordered, semi-crystalline spatial arrangement in the solid state, which gives the material exceptional physical properties. The atactic form, on the other hand, does not have any crystallinity. The most used industrial processes are directed towards the manufacture of isotactic polypropylene which is the one that has aroused the greatest commercial interest [24].

Polypropylene is the commercial polymer with the lowest density and ease of molding. It is used in a large number of sheets, fibers and filaments. Its properties include its high melting point (does not melt below 160 °C), high rigidity, high resistance to breakage and abrasion, dielectric properties, low friction, glossy surface and floating in water. It is resistant to acids, alkalis and many organic solvents. It is reheated close to 100 °C.

Polypropylene is sold with different molecular weights according to its purpose. In addition to polypropylene, a large number of copolymers of propylene exist on the market. The most important are those of propylene-ethylene [25].

2.4. Characterization of the Cocoa pod husks ashes

The characterization of this material follows an experimental procedure. First, the selection of the cocoa shell pods that are discarded during the pulping of the fruit is made. The drying is then carried out in a controlled atmosphere for 24 hours at a temperature of 65 °C, removing up to 50% of the humidity. Then, it is crushed and sieved in 2 mm meshes. The incineration of the sample is carried out in an isolated oven for 2 hours at an average temperature of 400 °C.

The ashes are sent to the X-Ray fluorescence laboratory of the National University of Colombia, where a semi-quantitative analysis is applied by means of a MagicPro PW-2440 Philips X-Ray fluorescence spectrometer. The results are shown in table 6.

Table 6. Characterization of the Cocoa pod husks ashes

Component	CVSC (% in weigh)
K ₂ O	72.08
CaO	11.57
P ₂ O ₅	5.42
MgO	4.12
SO ₃	3.09
SiO ₂	2.15
AlO ₃	0.39
MnO	0.26
Zn	0.24
Rb	0.23
Cl	0.14
Fe ₂ O ₃	0.07
Cu	0.07
TiO ₂	0.06
Cr	0.05
Sr	0.04
Na ₂ O	0.03

Among the most relevant components we can see 72.08% potassium oxide (K₂O), 11.57% Calcium Oxide (CaO), 5.42% Phosphorus Pentoxide (P₂O₅), 4.12% Magnesium Oxide (MgO), 3.09% Sulfur Trioxide and up to 2.15% Silicon Dioxide (SiO₂) commonly called silica. Each of these components is usable in different applications.

2.5. Mechanical design of the pneumatic injection machine using Autodesk Inventor Software.

The mechanical design includes the cylinder or shot sleeve with the respective closure cap, the feeding system of the material to be melted with the respective hopper, the injection nozzle holder of the injection mechanism and the structural base comprising all parts, mechanisms and systems of the machine.

2.5.1 Power Unit, injection and fusion. The injection unit corresponding to a storage container or cylinder with elements to meet the process [26].

The injection cylinder or sleeve must be a completely smooth cylinder, so that no friction is not generated at the time of injection and return of the piston, considering a hole at the top, for feeding material to be processed. Measures taken are: length 40 cm, internal diameter 3.81 cm and 5.1 cm outer diameter. The injection nozzle is made conical so that it can give a lace possible molds that are designed for a total sealing.

To the feed hopper, it was considered an angle allowing the sliding material and no clogging thereof is generated before entering the cylinder.

The closure cap of the cylinder is designed with a center of flexible material that can generate wear on the rod of the pneumatic actuator, therefore, its role is to close the injection cylinder to prevent outgassing when melting occurs and also adjusts the tire stem actuator not to generate oscillating motion in the plane x in the injection.

2.5.2 Support of the injection system and structural base of the machine. The machine stand is designed with the characteristic that must be robust, for the subject to be compression and bending in the structure. The injection process generates different effort by pneumatic actuator. The piece is designed in resistant steel compression and bending, grub to give fastening the cylinder and the machine base. The pneumatic actuator bracket fixed to said support base of the machine and likewise

helps give a parameter to center the machine or locate the injection cylinder in the same central axis of the actuator with the piston and rod. In part that is fixed to the base annealing is performed to fit the two parts and there is no possibility of movement.

The support base is designed in a rectangle 40 cm wide and 26 cm deep so that it can have a working area at the time of placing the molds for injection. To the support column of the machine, a steel is recommended seamless to generate a compressive strength greater degree, it is designed taking into account the height of the injection cylinder, with a length of 67.5 cm and an inner diameter of 3.81 cm.

Given the given specifications, modeling of machine support is performed, similarly a design on a table is performed to give a working height for the operator to perform a better process, all the above is shown in Figure 1.

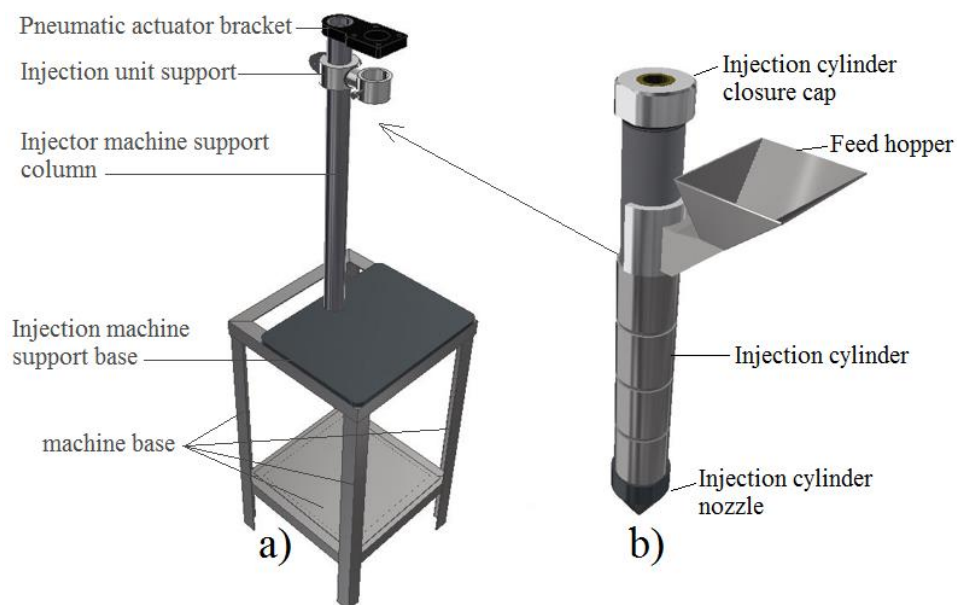

Figure 1. Mechanical design of the injection machine. a) support of the injection unit; b) Injection and fusion unit.

For this system, a piston design that will exert pressure on the material is also a patterned assembly actuator using the solenoid valves is made.

For a design part is made in nodular steel to be displaceable on the cylinder or sleeve of the fuel without causing any damage to the same surface, preventing leaks that may cause clogging in the injection.

Measurement was according piston into the cylinder injection in the case is 3.81 cm. For modeling, injection system takes into account the pneumatic actuator, which must meet a stipulated career to fulfill the operation, just as a solenoid valve is included with their respective assembly maintenance unit to perform an injection with a specified position. In Figure 2, the design is observed.

2.6. Pneumatic injection machine automation

The injection of plastic required a control system that allows closed loop to the automatic process. The process has the following steps, preheating cylinder, heating the plastic to melt it and then injected into a mold; in order to have a product with an established form and a semirecycled material.

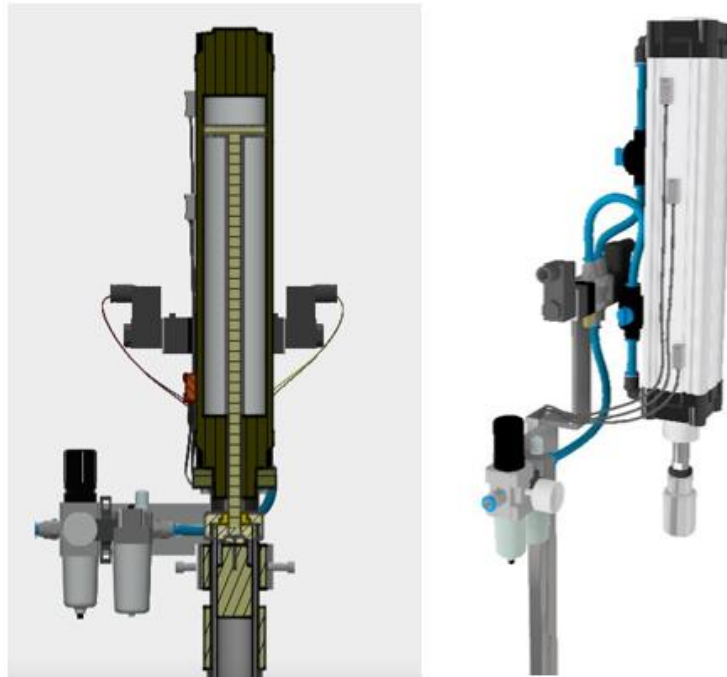

Figure 2. Injection system with pneumatic actuator

2.6.1 Circuit electronic. Depending on the automatic process that you want to play on the injector, an electrical circuit is deployed that can take control of all the variables involved in the process.

2.6.1.1 Subsystems process. Subsystems used in the process are: Temperature (electric heaters), has five resistors distributed evenly to uniformly heat the liner (cylinder), also has three thermocouples which measure the temperature in real time of the same. Tire (piston) is formed by a pneumatic actuator which raises and lowers the injection piston, three position sensors on one side of the actuator for opening, closing and injection of the material and a directional solenoid 5 way three position closed center. Interactive Control Software (LabVIEW), the subsystem hardware consists of an Arduino UNO and their respective modules to receive information and broadcast it to a computer with LabVIEW software that controls the process.

Table 7. Electronic components

Quantity	Component	Characteristic
3	Temperature sensor	Measuring range 0 ° to 350 ° C
5	Electric resistance	Power 280 W and 100 W
1	directional solenoid valve	Pneumatic valve 5 way / 3-position
3	Position sensors	Magnetic sensor
3	Isolating circuit coupled	Handle different voltages in a circuit
1	Arduino Uno	ADC 10 bits volt 0-5 v
1	2-channel relay module	Digital pins 120 v - 1 A
1	4 channel relay module	Digital pins 120 v - 1 A
3	Analog to digital converter for Thermocouple	Vcc: 5 v - Icc: 1.5 mA

2.6.2 Programming Software LabVIEW. It allows you to read signals, process and act in real time. The programming language compiler is the block diagram and also to create an interactive interface of the whole process. Here it is shown that the programming code for the injection molding process.

All programming is inside a while loop structure, so as to be continuous reading data. Inside is a structure "case" to have a manual option (False) and a sequential autonomous (true).

The interactive image program allows you to control all elements of the fuel through five (5) boolean switches within the program:

- Solenoid 1 directional valve (V1, Lower piston).
- Solenoid 2 directional valve (V2, Up piston).
- Heat resistance 1 (R1).
- Heat resistance 2 (R2).
- 3 Thermal resistance (R3).

The solenoids of the valves are conditioned so that only moving between the sensors S1 and S3. The only activate this contrary to the direction of the current position.

Additionally it has temperature readings of the three points (T1, T2 and T3), which have an ON-OFF system and a set temperature, which is not exceeded. It also has reading piston position (S1, S2, S3).

The interactive interface allows the observation made: the temperatures of the fuel, the piston position, the phase of the sequence found and the elapsed time of each phase. It also has interactive animations that make the process. All this is shown in Figure 3.

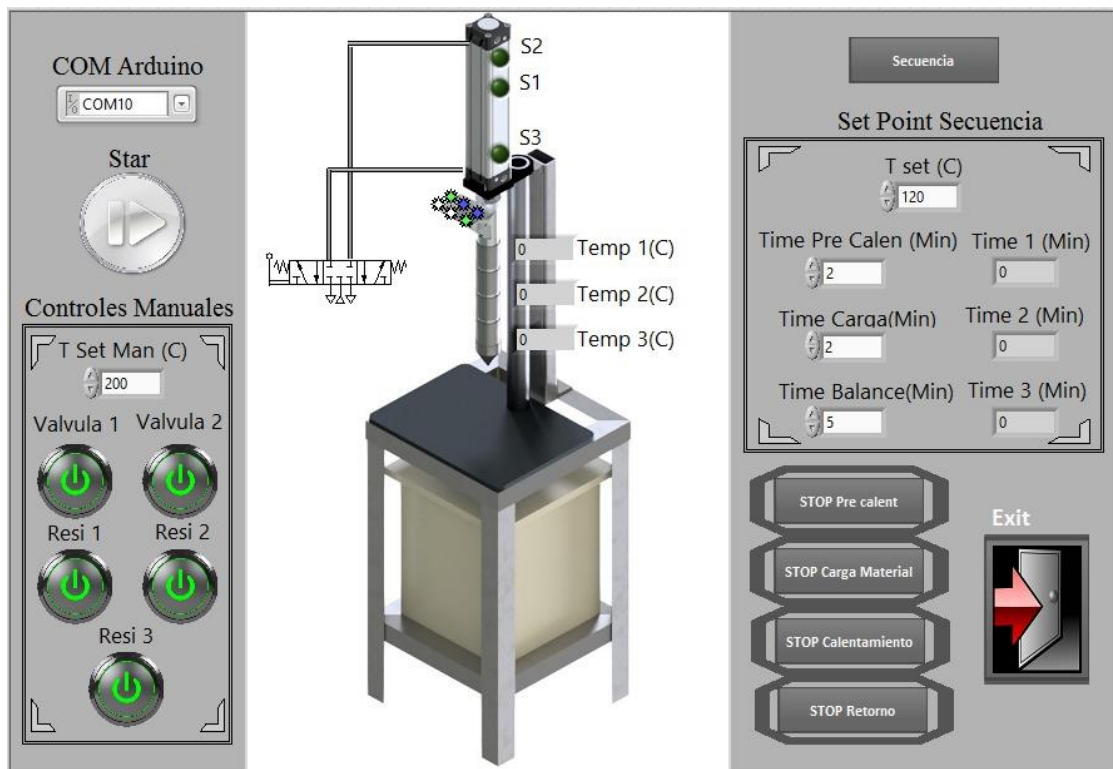

Figure 3. Interactive interface.

2.7. Construction of the automated pneumatic injection machine with LabVIEW Software.

It based on the mechanical design automation equipment, construction proceeds with recommendations for each element, system and mechanism of the machine materials; resulting in the equipment shown in Figure 4.

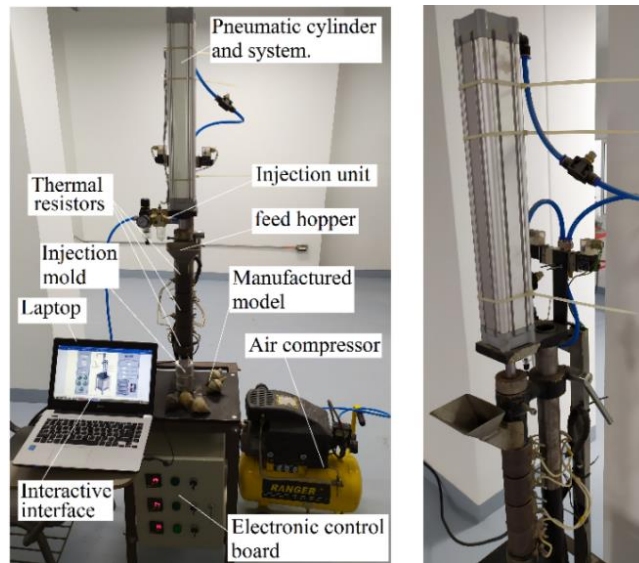

Figure 4. Final image of the automated pneumatic injector with all systems and mechanisms.

2.8 Application of experimental tests.

For this process, different mix designs mass fraction between polypropylene resin (PP), polyethylene terephthalate recycled in flake form (R-PET) and sheath ash cocoa shell (CPHA) are performed. These components can be seen in Figure 5.

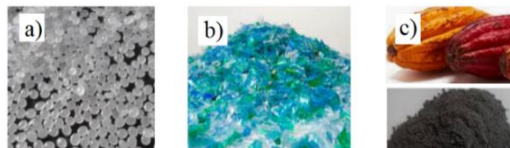

Figure 5. Raw material. a) Polypropylene resin PP; b) Recycled polyethylene terephthalate in the form of scales R-PET; c) Cocoa pod husks ashes CPHA

Having defined the raw material, the testing for three (3) types of mix designs, recording the mass fractions, melting temperatures and times, the photographic record of the final piece and applied pressure injection are performed. All this is summarized in Tables 8,9 and 10.

Table 8. Design of components and manufacturing specifications of model A

Test Format: Model A						
 Photography model A	Test number:		1	Mold:	Trompo	
	Component design					
	PP	80 g	R-PET	---	CPHA	---
		100%		0%		0%
	Preheating (minutes)				10	
	Melting time of the mixture (minutes)				25	
	Maximum temperature (°C)				300	
	Injection time (seconds)				30	
	Injection pressure (psi _a)				80	
	Morphological appearance				95%	
Observations: The manufactured piece has a homogeneous morphological appearance and an almost transparent color, the density remains stable. The molten raw material has a high viscosity, therefore the pressure and injection time increase.						

Table 9. Design of components and manufacturing specifications of model A



Test Format: Model B						
 <p>Photography model B</p>	Test number:		1	Mold:	Trompo	
	Component design					
	PP	40 g	R-PET	40 g	CPHA	---g
		50%		50%		0%
	Preheating (minutes)				10	
	Melting time of the mixture (minutes)				20	
	Maximum temperature (°C)				300	
	Injection time (seconds)				12	
	Injection pressure (psi _a)				70	
	Morphological appearance				96%	
<p>Observations: The manufactured part has a morphological appearance and a homogeneous color, although it is important to clarify that the color depends on the R-PET used and on which containers it was recycled. On the other hand, the viscosity of the molten mixture decreases with respect to the model with 100% PP, this due to the chemical and physical properties of R-PET, requiring a lower pressure and injection time.</p>						

Table 10. Design of components and manufacturing specifications of model C

Test Format: Model C						
 <p>Photography model C</p>	Test number:		1	Mold:	Trompo	
	Component design					
	PP	32 g	R-PET	32 g	CPHA	16 g
		40%		40%		20%
	Preheating (minutes)				10	
	Melting time of the mixture (minutes)				19	
	Maximum temperature (°C)				280	
	Injection time (seconds)				10	
	Injection pressure (psi _a)				65	
	Morphological appearance				98%	
<p>Observations: The manufactured piece has a homogeneous morphological appearance and the grayish color is due to the incorporation into the cocoa pod husks ash mixture. Also, it could be shown that the viscosity of the molten mixture decreases, therefore, a lower pressure and injection time is needed compared to the 100% PP model</p>						

3. Conclusions

An automated injection machine was designed and implemented to obtain a hybrid piece that takes advantage of the ashes of the cocoa shell pod and reuses PET bottles that are recycled and crushed in the form of scales. All this, in order to incorporate this waste into a thermoplastic element that can be used again. In addition, the control system operates on the LabView computer platform, through the Arduino architecture.

The final product is characterized in that the process is controlled in pressure limits and injection times. In addition to the maximum temperature of the mixture incorporated in the fusion cylinder, which are configurable in the application of a PC computer. Finally, and after several tests, three (3)

types of models (A, B and C) are selected to which a mass-based mixture of each of its components (PP resin, R-PET and CPHA).

The morphological aspect of all models was homogeneous by up to 98%. Also, it was found that R-PET is used up to 50% and even more.

By incorporating a greater amount of R-PET in the mixture (e.g. up to 50% on a mass basis), the viscosity decreases at the time of fusion, compared to the fusion of model A composed of 100% PP resin; needing a lower pressure and injection time.

The addition of CPHA in the mixture provides a model with a homogeneous and gray-gray appearance, but the most interesting thing is that the biodegradability properties increased by the addition of this compound, because it provides CaO, which in turn absorbs CO₂ from the environment, producing condensation on the surface of the final model.

References

- [1] Karel Š and Achten H 2017 *Experimental development of a plastic bottle usable as a construction building block created out of polyethylene terephthalate : Testing PET (b) rick J. (Build Eng vol 12 No May) pp 239–247*
- [2] Mwanza B G and Mbohwa C 2017 *Drivers to Sustainable Plastic Solid Waste Recycling : A Review (Procedia Manuf vol 8 No October) pp 649–656*
- [3] Liu H Wu Q and Zhang Q 2009 *Bioresource Technology Preparation and properties of banana fiber-reinforced composites based on high density polyethylene (HDPE) / Nylon-6 blends (Bioresour Technol vol 100 No 23) pp 6088–6097*
- [4] Palma-ramírez D Torres-huerta A M De Fuente D and Pla P E 2019 *Data supporting the morphological / topographical properties and the degradability on PET / PLA and PET / chitosan blends (Data in Brief vol 25) pp 1-23*
- [5] Lahimer M C 2017 *Characterization of plastic packaging additives : Food contact , stability and toxicity (Arab J Chem vol 10) pp S1938–S1954*
- [6] Yu L Dean K and Li L 2006 *Polymer blends and composites from renewable resources (Progress in Polymer Science vol. 31) pp 576–602*
- [7] Sorgato M Masato D and Lucchetta G 2018 *Tribological effects of mold surface coatings during ejection in micro injection molding (J Manuf Process vol. 36 No August) pp. 51–59*
- [8] Sorgato M Masato D Lucchetta G and Orazi L 2018 *Effect of different laser-induced periodic surface structures on polymer slip in PET injection moulding (CIRP Annals vol 67 No 1) pp 575–578*
- [9] Sánchez-Alvarez A Luna-Moreno Q D Hernández-Morales J A Zaragoza-Zambrano J O and Castillo-Guerrero D H 2018 *Control of Stepper Motor Rotary Stages applied to optical sensing technique using LabView (Optik (Stuttg) vol 164) pp. 65–71*
- [10] Zhang Y Li Y Gu X Liu H Zhang Y and Hu W 2019 *Laser spot image acquisition and processing based on LabVIEW (Optik (Stuttg) vol 185 No November) pp 505–509*
- [11] Beyaz A 2018 *Harvest glove and LabView based mechanical damage determination on apples (Sci. Hortic (Amsterdam) vol 228 No September) pp. 49–55*
- [12] Mahmoodi M James L A and Johansen T 2018 *Automated advanced image processing for micromodel flow experiments ; an application using LabVIEW (J Pet Sci Eng vol 167 No November) pp 829–843*
- [13] Mitra A C Jagtap A and Kachare S 2018 *Development and Validation of Experimental Setup for Flexural Formula of Cantilever Beam Using NI-LabVIEW (Mater Today Proc vol. 5 No 9) pp. 20326–20335*
- [14] La Mantia F P Morreale M Botta L Mistretta M C and Scaffaro R 2017 *Degradation of polymer blends : A brief review (Polym Degrad Stab vol 145 pp 79–92*
- [15] Hahladakis J N and Iacovidou E 2018 *Closing the loop on plastic packaging materials: What is quality and how does it affect their circularity? (Sci Total Environ vol 630) pp 1394–1400*

- [16] Kenny M Peponi L Puglia D Torre L and Valentini L 2014 *Processing of nanostructured polymers and advanced polymeric based nanocomposites (Mater Sci Eng R Reports vol 85)* pp 1–46, 2014.
- [17] Siracusa V Dalla M Romani S and Rocculi P 2011 *Life Cycle Assessment of multilayer polymer film used on food packaging field (Ital Oral Surg vol 1)* pp 235–239
- [18] Prambauer M Wendeler C Weitzenböck J and Burgstaller C 2019 *Geotextiles and Geomembranes Biodegradable geotextiles – An overview of existing and potential materials (Geotext Geomembranes vol. 47 No 1)* pp 48–59
- [19] Taneli V 2017 *A review on new bio-based constituents for natural fiber-polymer composites (J Clean Prod vol 149)* pp 582–596
- [20] Groh K J et al 2019 *Overview of known plastic packaging-associated chemicals and their hazards (Sci Total Environ vol 651)* pp 3253–3268
- [21] Zhang Z Wang C and Mai K 2019 *Advanced Industrial and Engineering Polymer Research Reinforcement of recycled PET for mechanical properties of isotactic polypropylene (Adv Ind Eng Polym Res vol 2 No 2)* pp 69–76
- [22] Coreño-Alonso J and Méndez-Bautista M T 2010 *Relación estructura - propiedades de polímeros (Educ Química vol 21 No 4)* pp 291–299
- [23] Báez J E 2016 *El crecimiento en los extremos: Reactividad de grupos terminales en polímeros para la síntesis de copolímeros bloque (Educ Quím vol 27 No 2)* pp 97–104
- [24] Serrano Hernández L Barceló Santana F H and Santos Espinoza A 2013 *Deflexión transversa de materiales alternativos a base de polímeros para fabricación de base de dentadura (Rev Odontológica Mex vol 17 No 3)* pp 146–151
- [25] Eduardo B J Pedro R O Bogart M U Camille and Claudia Marcela G B 2013 *Desarrollo de un material compuesto ultraligero para construir la plataforma de una mesa vibradora (Ing Investig y Tecnol vol 14 No 4)* pp 595–611
- [26] Dahlbo H Poliakova V Mylläri V Sahimaa O and Anderson R 2018 *Recycling potential of post-consumer plastic packaging waste in Finland (Waste Manag vol 71)* pp 52–61